

OTMSL-MID COMBI 154 TD

COMPACT BLOCK

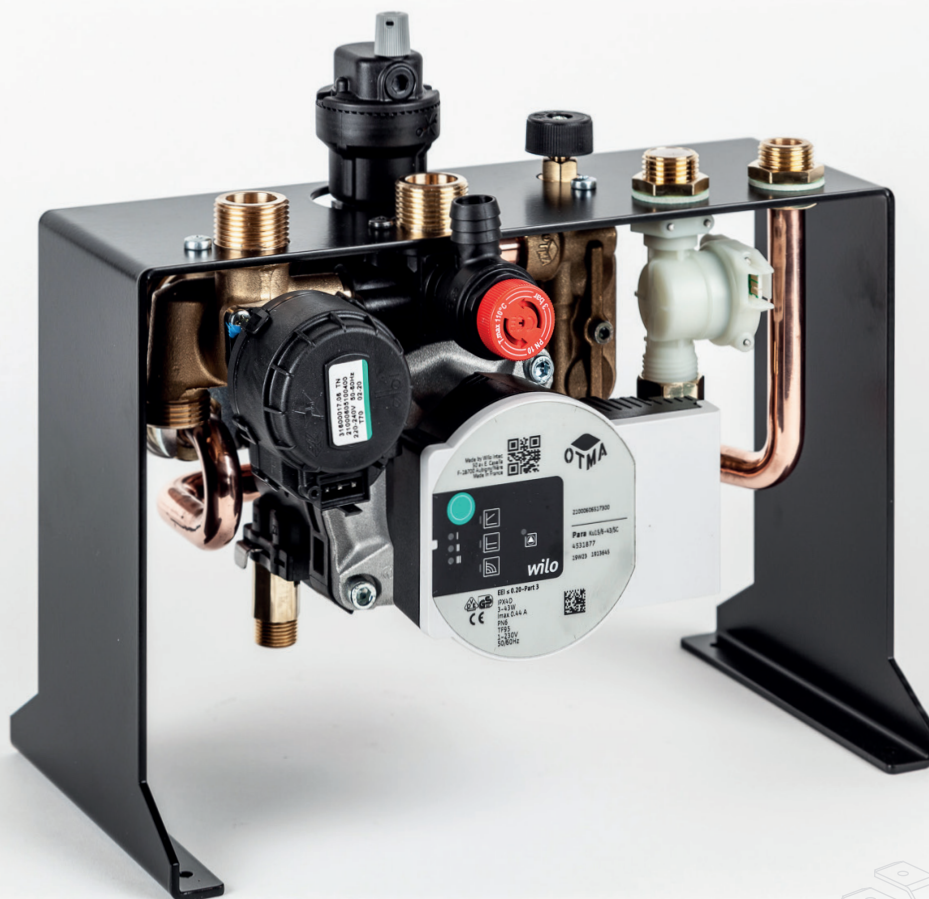

Gruppo idraulico compatto per caldaie con scambiatore monoterminico

- / Produzione di acqua calda sanitaria con scambiatore a piastre
- / Riscaldamento ambiente

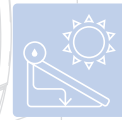

www.otma.it

OTMSL-MID COMBI 154 TD

COMPACT BLOCK

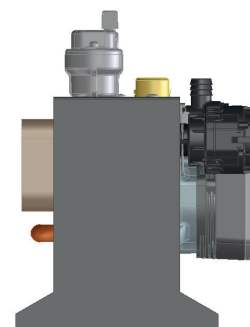
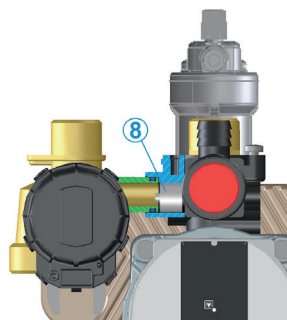
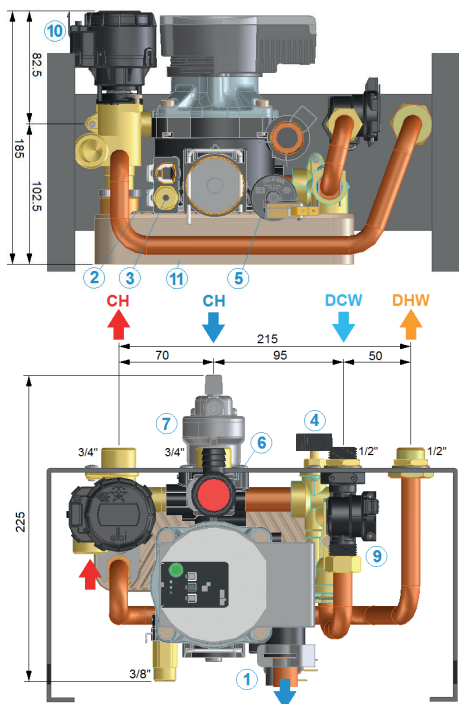

/ schema idraulico

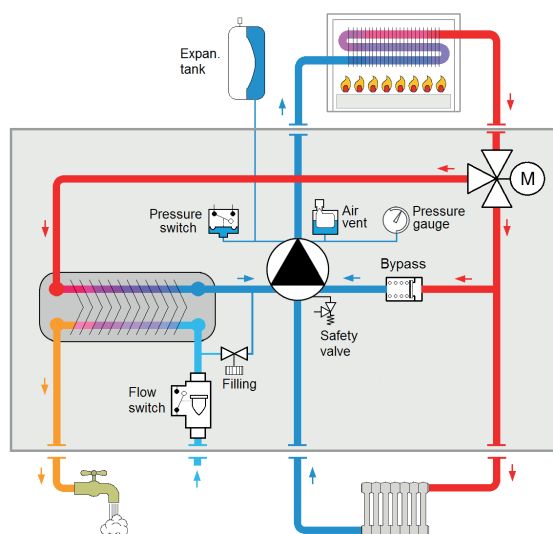

/ curve caratteristiche

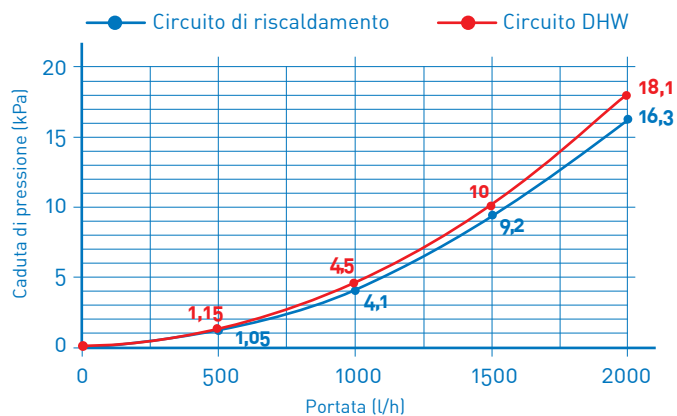

- 1 Pompa
- 2 Connessione manometro
- 3 Connessione vaso di espansione
- 4 Valvola di riempimento
- 5 Pressostato
- 6 Valvola di sicurezza
- 7 Valvola sfogo aria
- 8 Valvola bypass
- 9 Flussimetro
- 10 Valvola 3-vie
- 11 Scambiatore a piastre

/ dati tecnici

Potenza massima: **35 kW**

Temperatura massima: **95 °C**

Pressione CH: **0.3 - 3 bar**

Pressione DHW: **0.15 - 10 bar**

Portata DHW

in apertura: **2 l/min ± 0.2**

in chiusura: **1.5 l/min ± 0.2**