

OTMSL-DX OH TD

COMPACT BLOCK



Compact hydroblock for heating only boiler

/ Room heating

www.otma.it

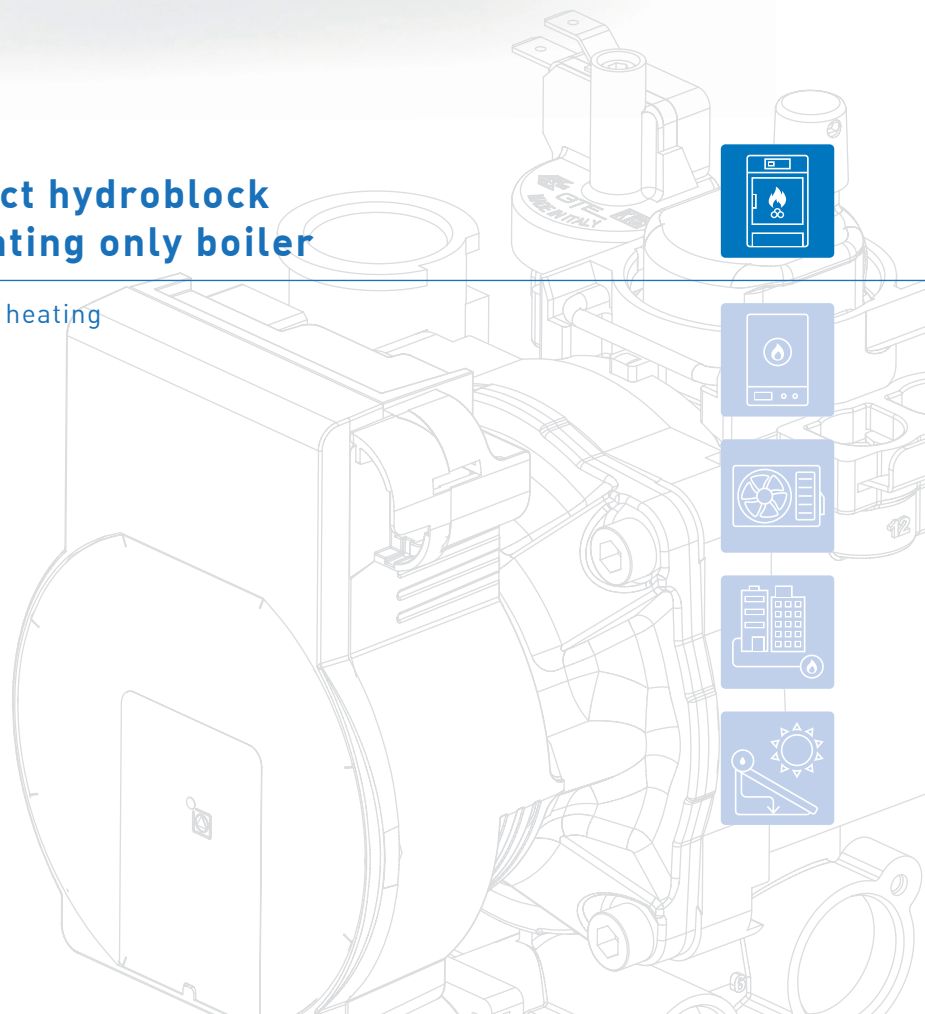

OTMSL-DX OH TD

COMPACT BLOCK

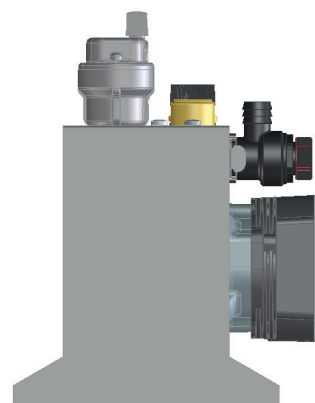
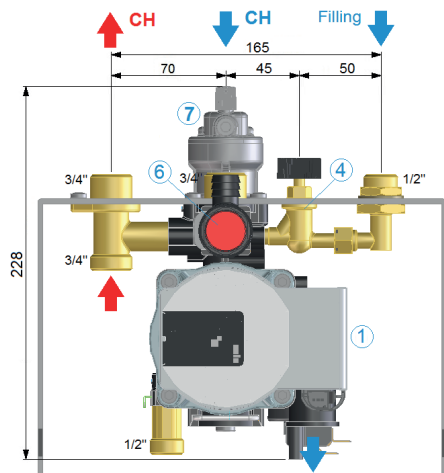
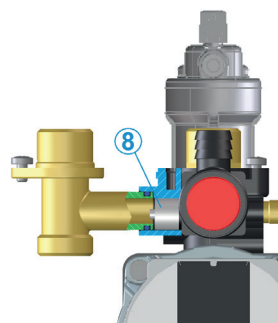
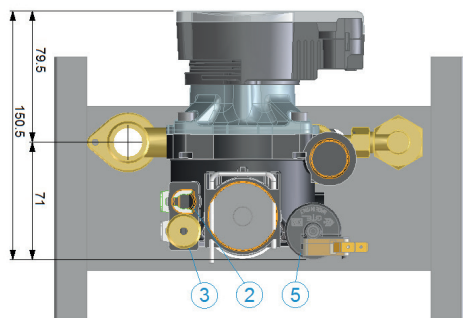

- 1 Pump
- 2 Manometer connection
- 3 Expansion tank connection
- 4 Filling valve
- 5 Pressure switch
- 6 Safety valve
- 7 Air vent valve
- 8 Bypass valve

/ hydraulic scheme

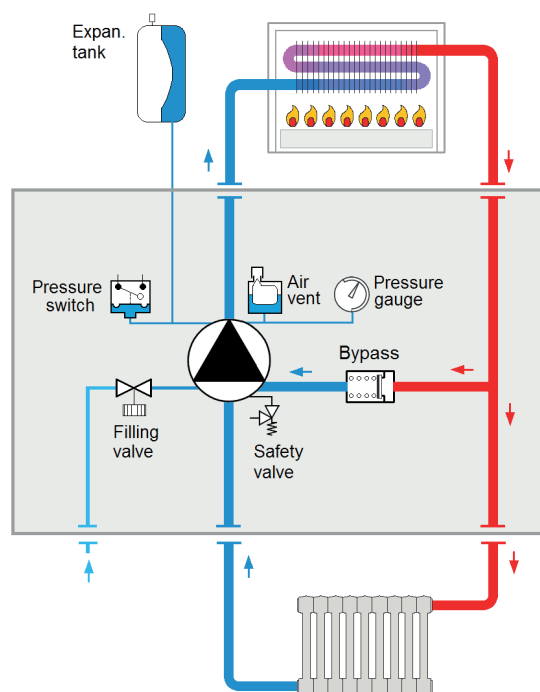

/ technical data

Max power: **35 kW**
 Max temperature: **95 °C**
 Pressure CH: **0.3 - 3 bar**