

/ OTMSL-DX TANK TD

COMPACT BLOCK

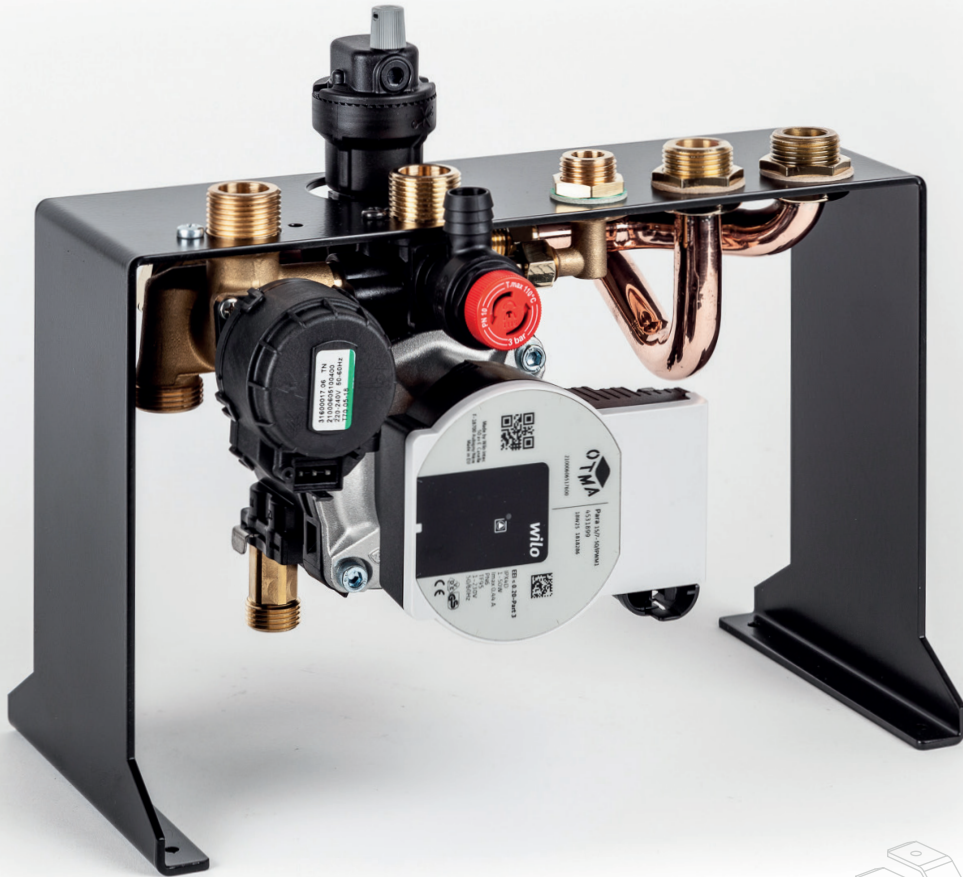

Compact hydroblock for boiler with storage tank

- / Domestic hot water production
- / Room heating

/ www.otma.it

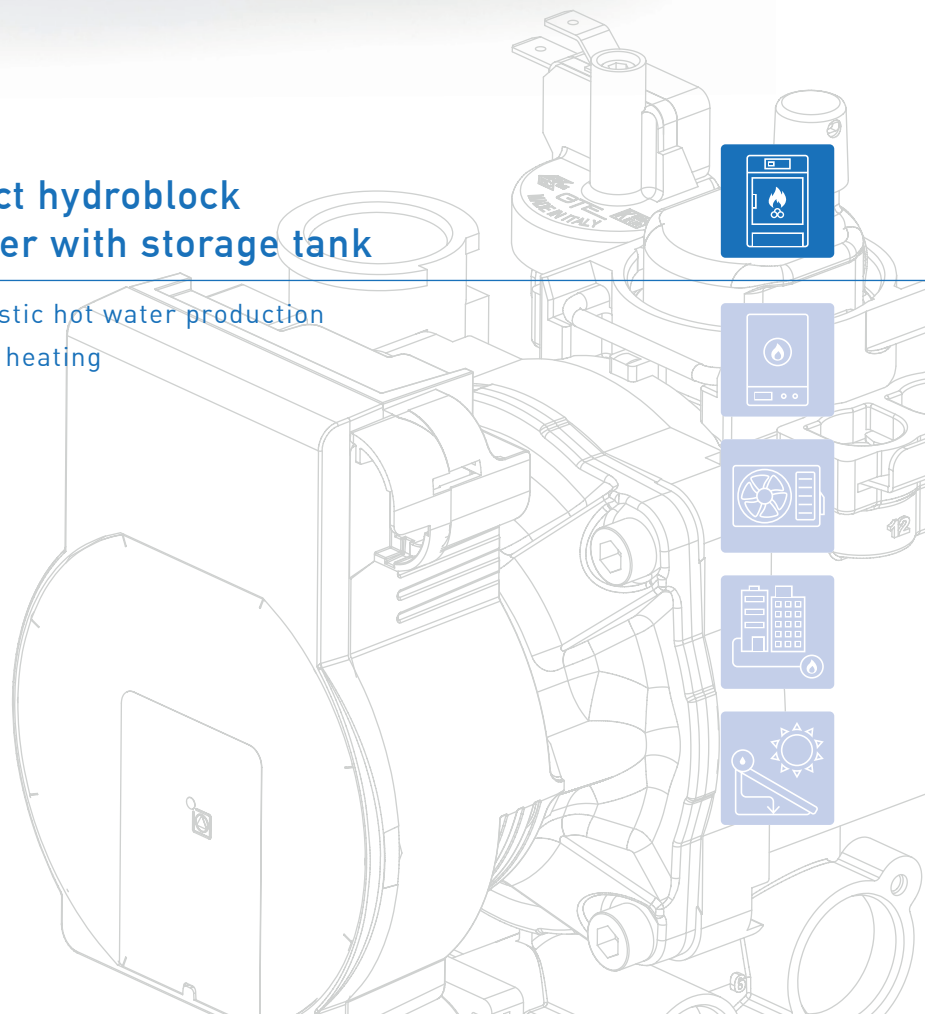

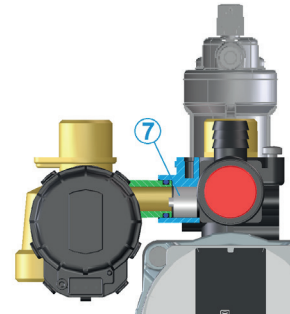
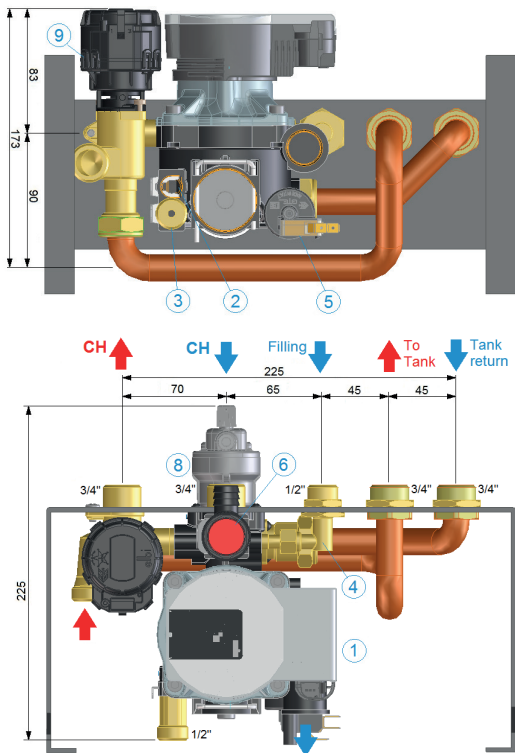

/ hydraulic scheme

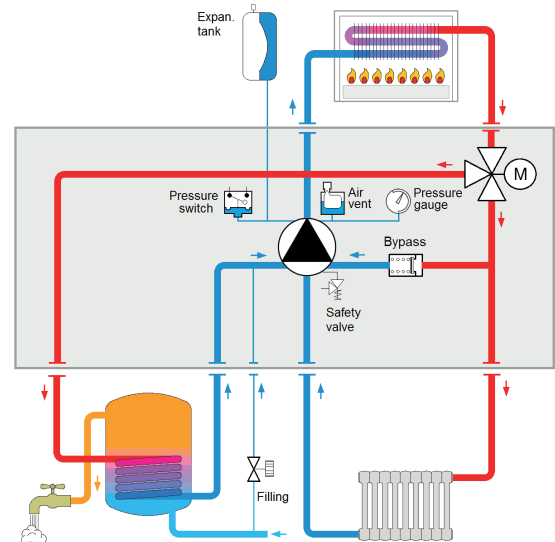

- 1 Pump
- 2 Manometer connection
- 3 Expansion tank connection
- 4 Filling connection
- 5 Pressure switch
- 6 Safety valve
- 7 Bypass valve
- 8 Air vent valve
- 9 3-way valve

/ technical data

Max power: 35 kW
 Max temperature: 95 °C
 Pressure CH: 0.3 - 3 bar

/ characteristic curves

